

Audio

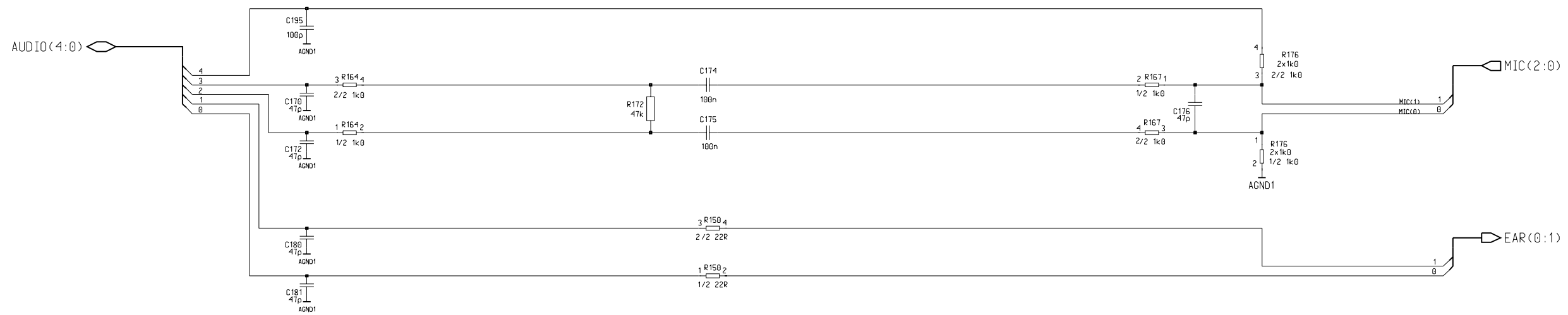

AUDIO

Circuit Diagram of RX

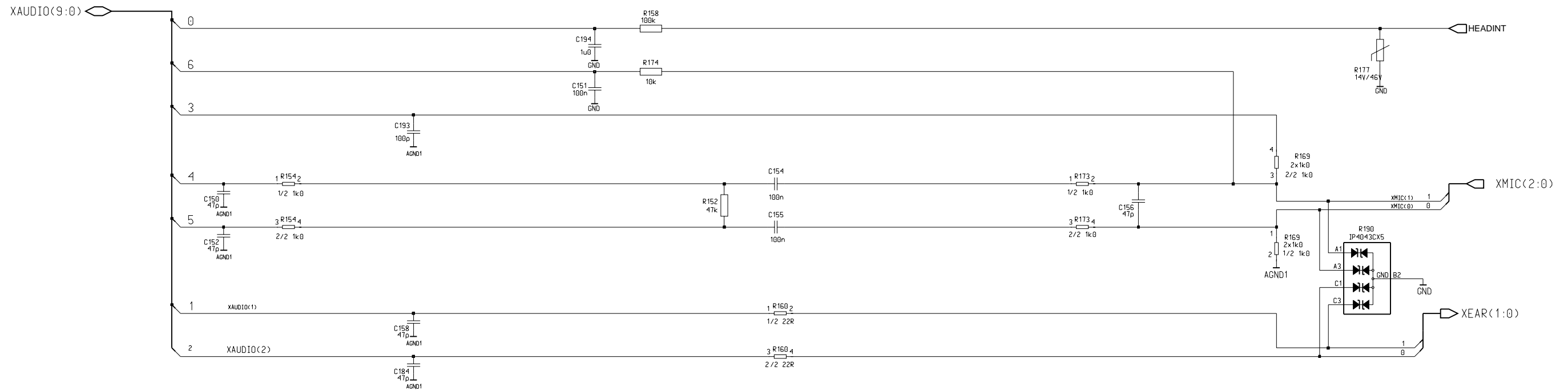
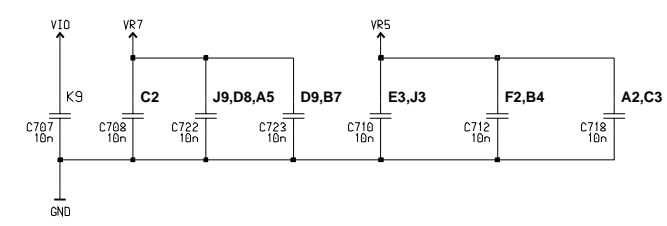
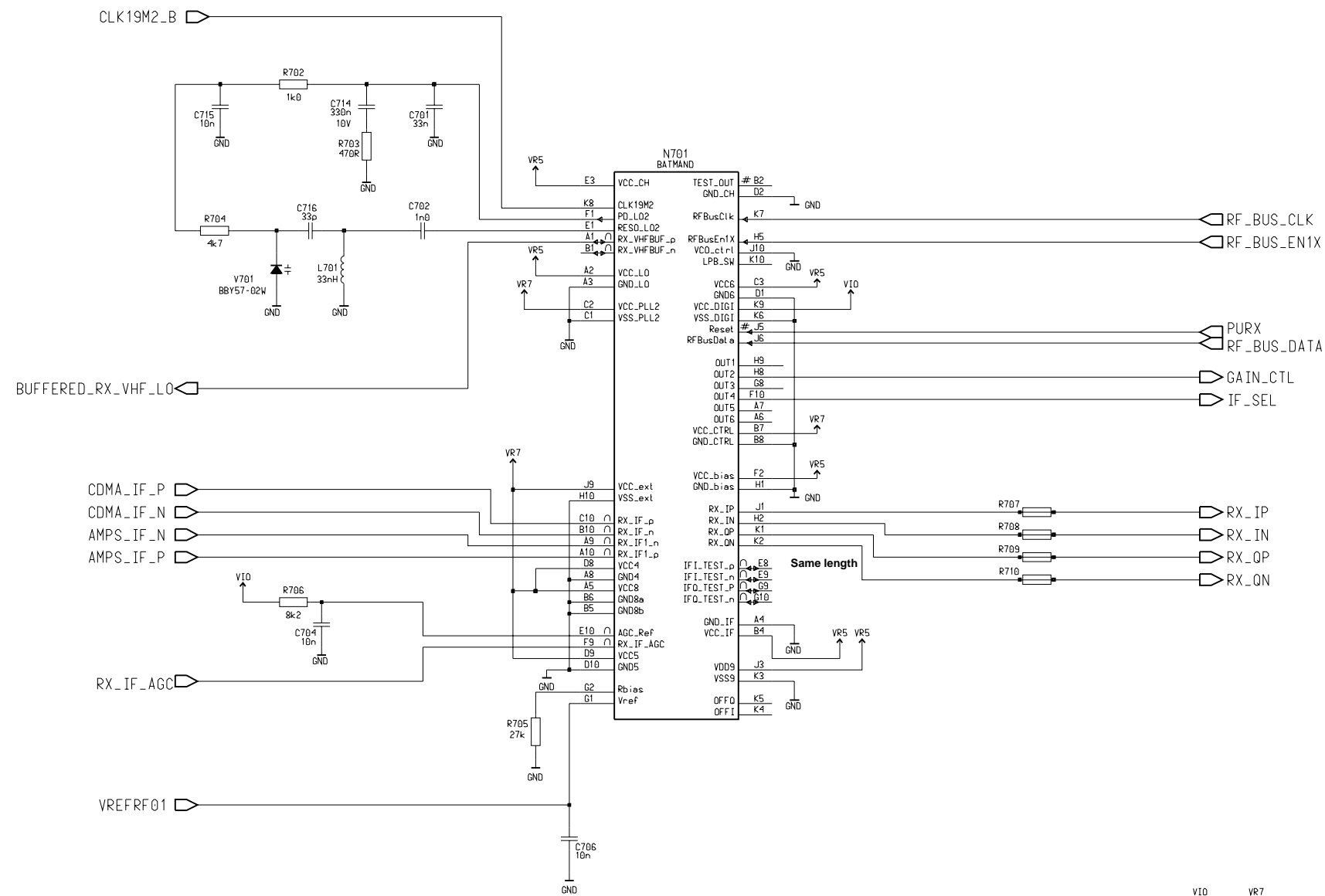

Circuit Diagram of BB

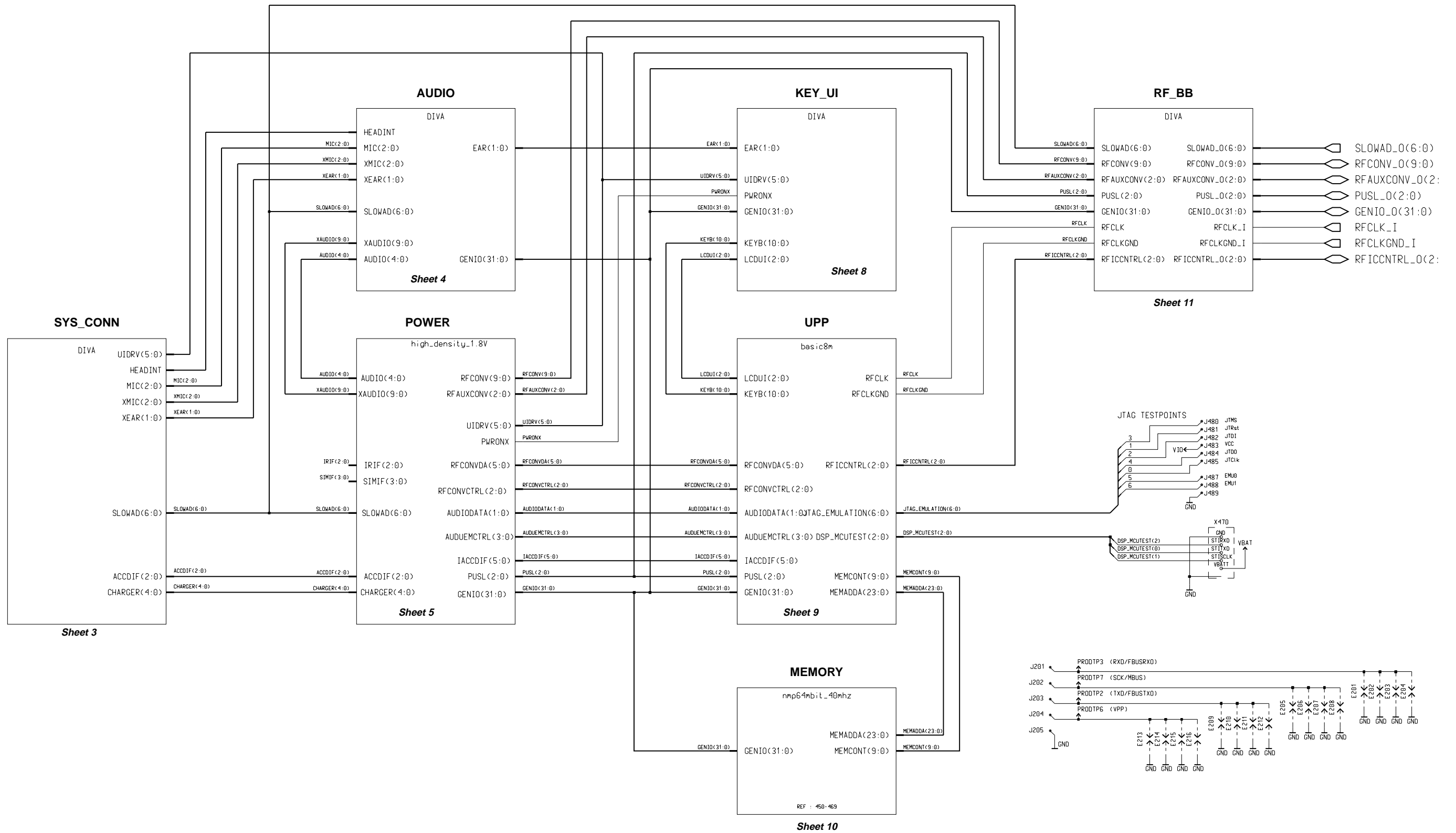

Components: 420-439
 Component s: 300-349
 Component s: 350-355
 POWER Component s: 200-299
 STEPUP Component s:260-269
 DC/DC Component s:270-299
 AUDIO Component s: 150-199
 ANCO Component s: 170-199
 SYS_CONN Component s: 100-129
 HEADSET Component s: 120-129
 Component s: 400-419

DC/DC Converter

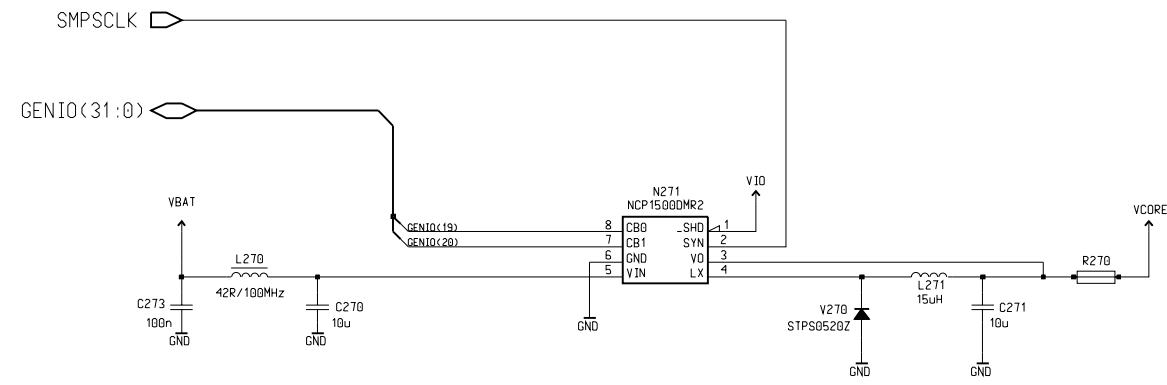

Circuit Diagram of RX front end

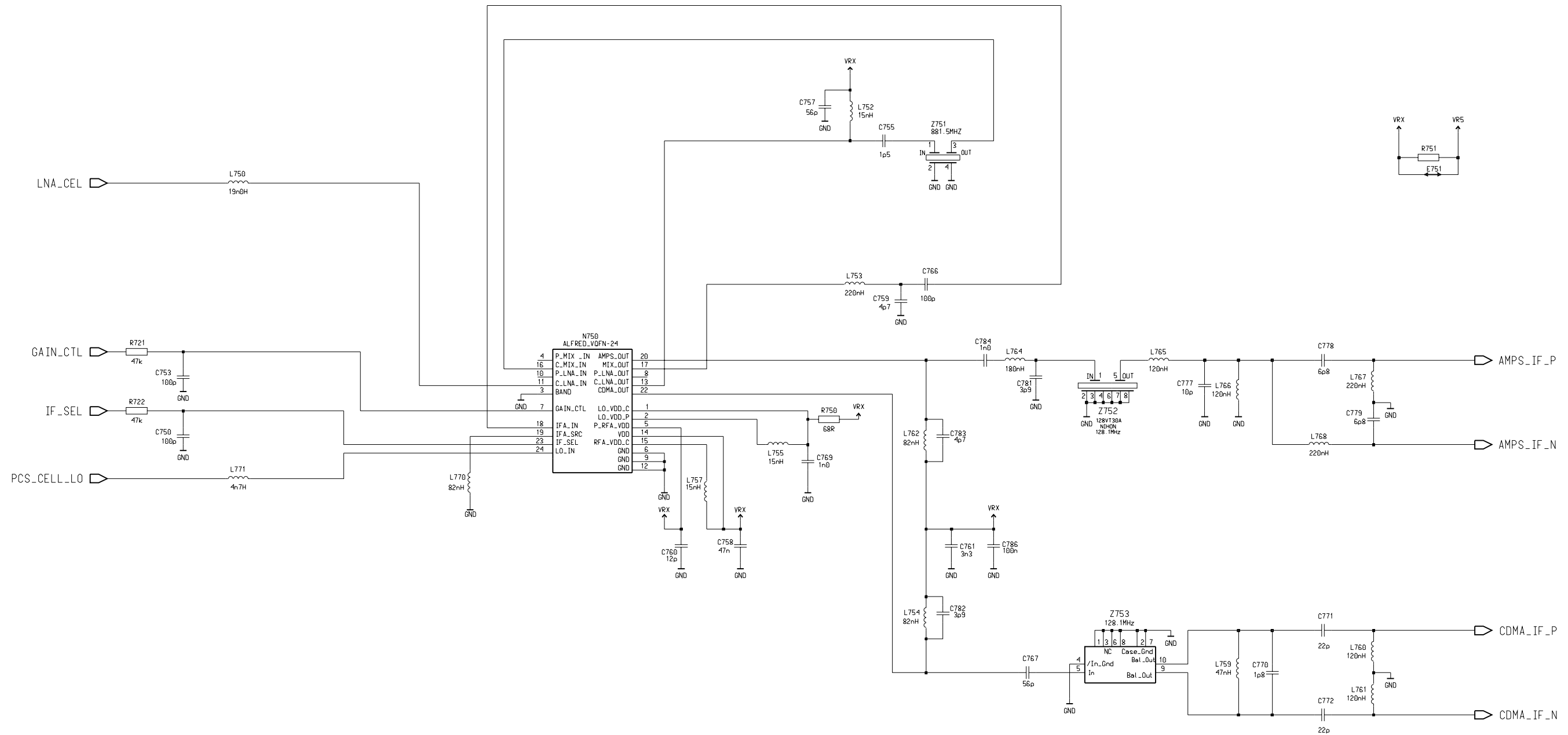

Circuit Diagram of PA

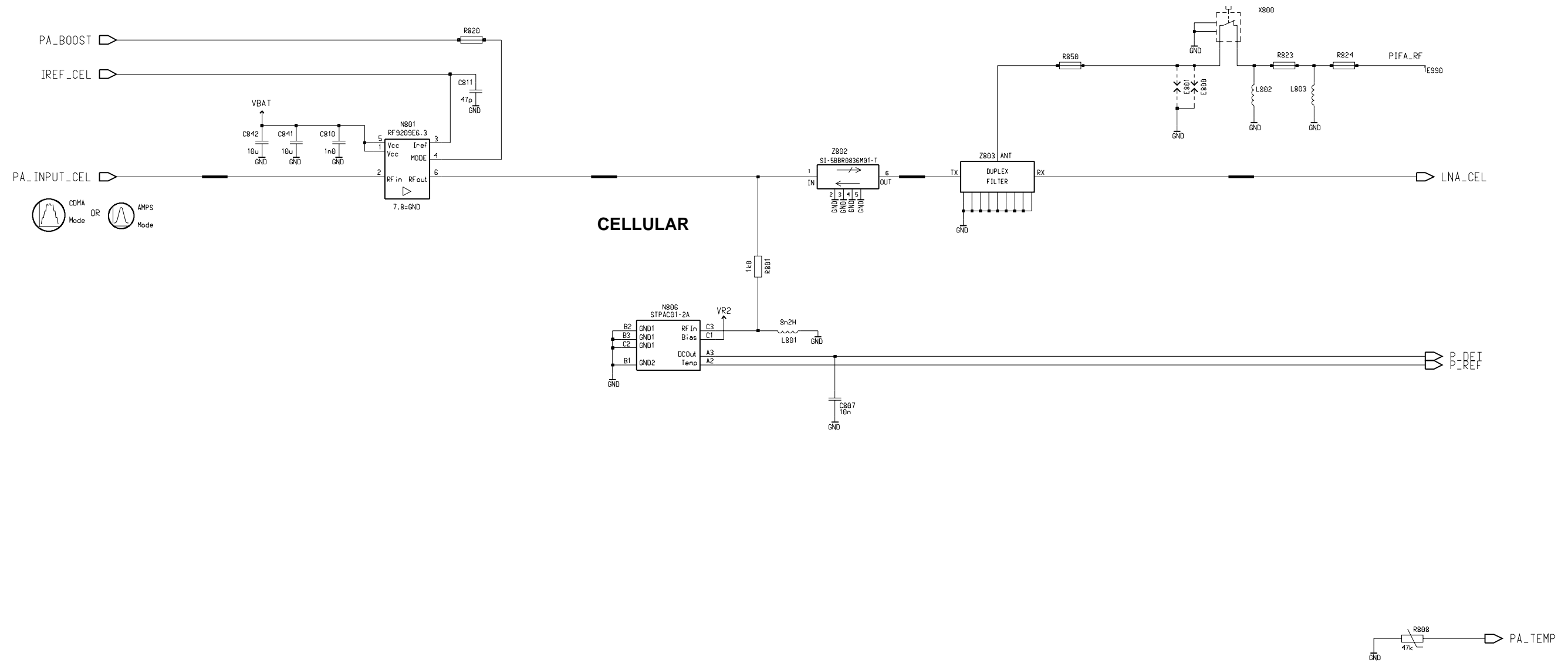

Circuit Diagram of RF

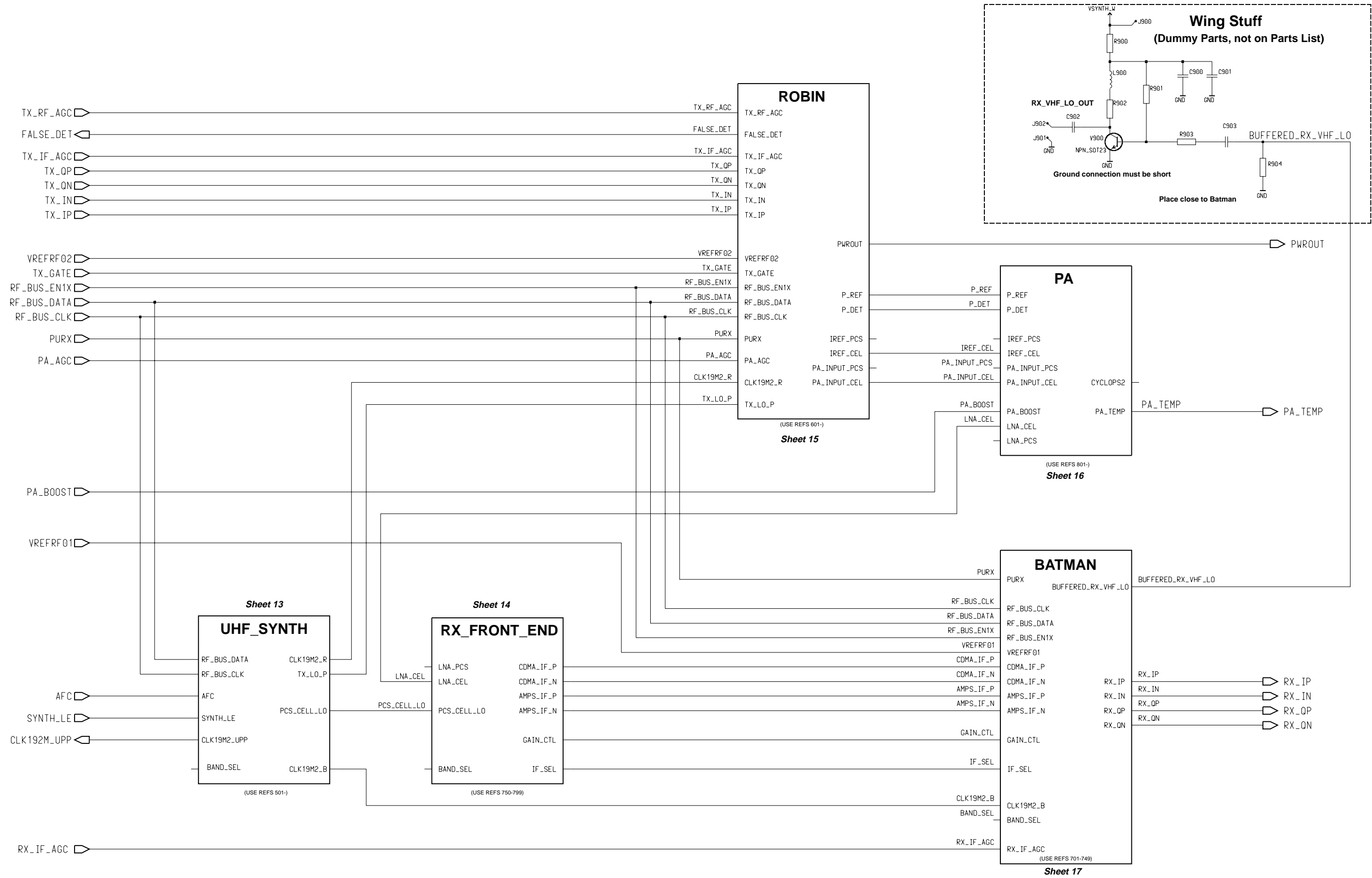

RF-BB

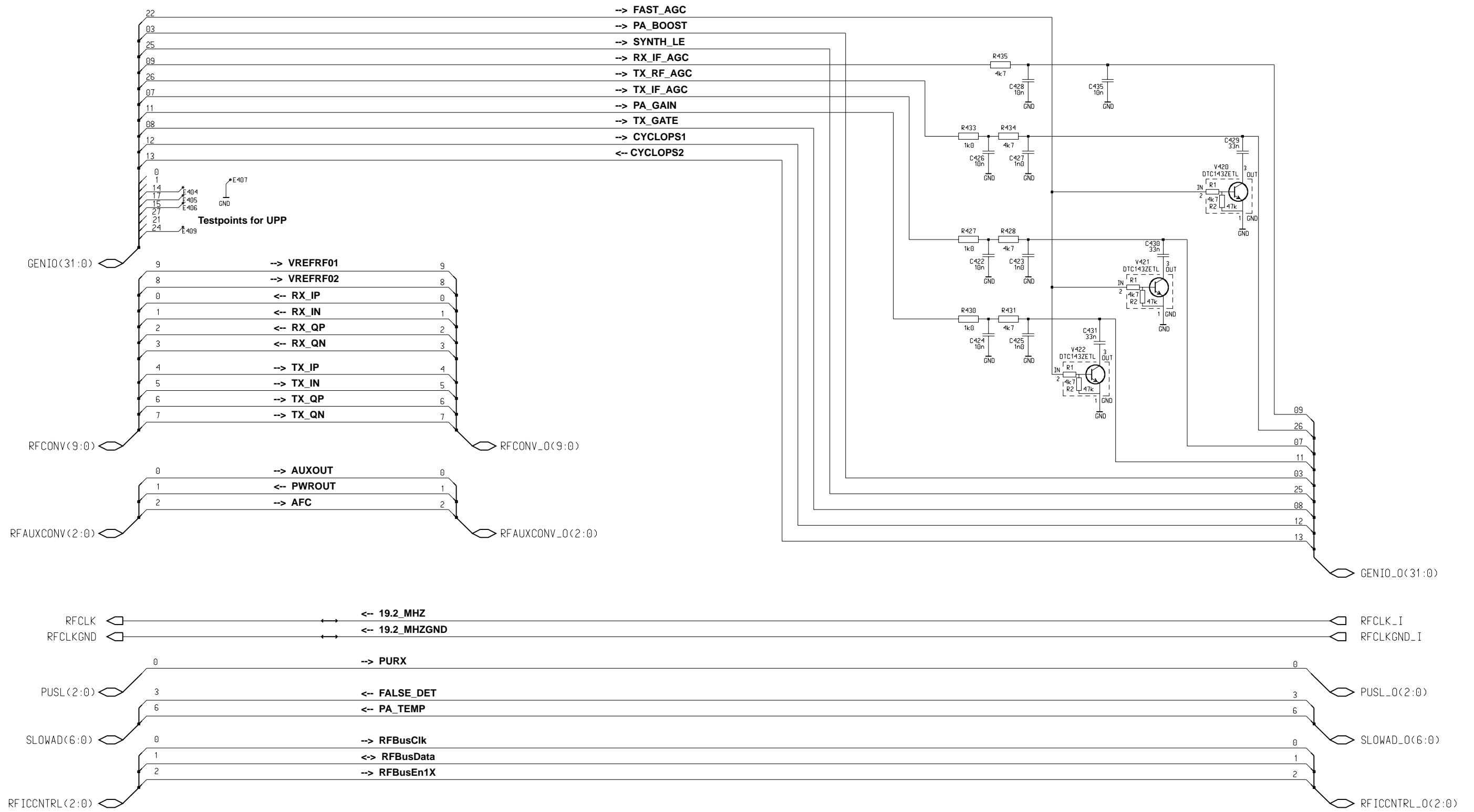

Circuit Diagram of TX

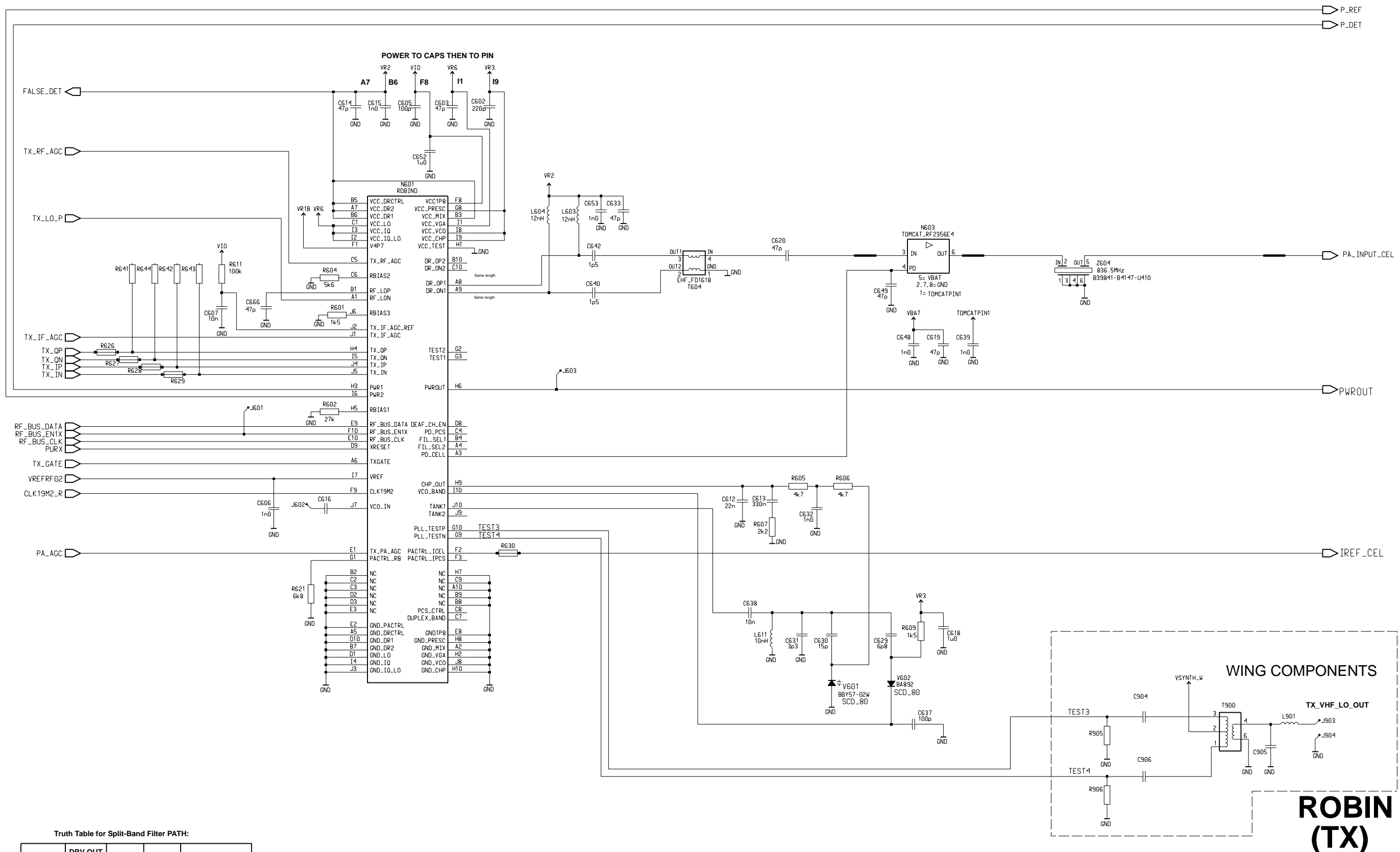

Truth Table for Split-Band Filter PATH:

DRV CNTL	DRV OUT STATE	VCONT1	VCONT2	SWITCH IN STATE
0 volt	RFOUT1	0 volt	2.7 volt	RFI1
2.7 volt	RFOUT2	2.7 volt	0 volt	RFI2

VCO_BAND	
Cell band	low (shorted to ground)
PCS band	tri-stated (open circuit)

ROBIN (TX)

UHF Synthesizer

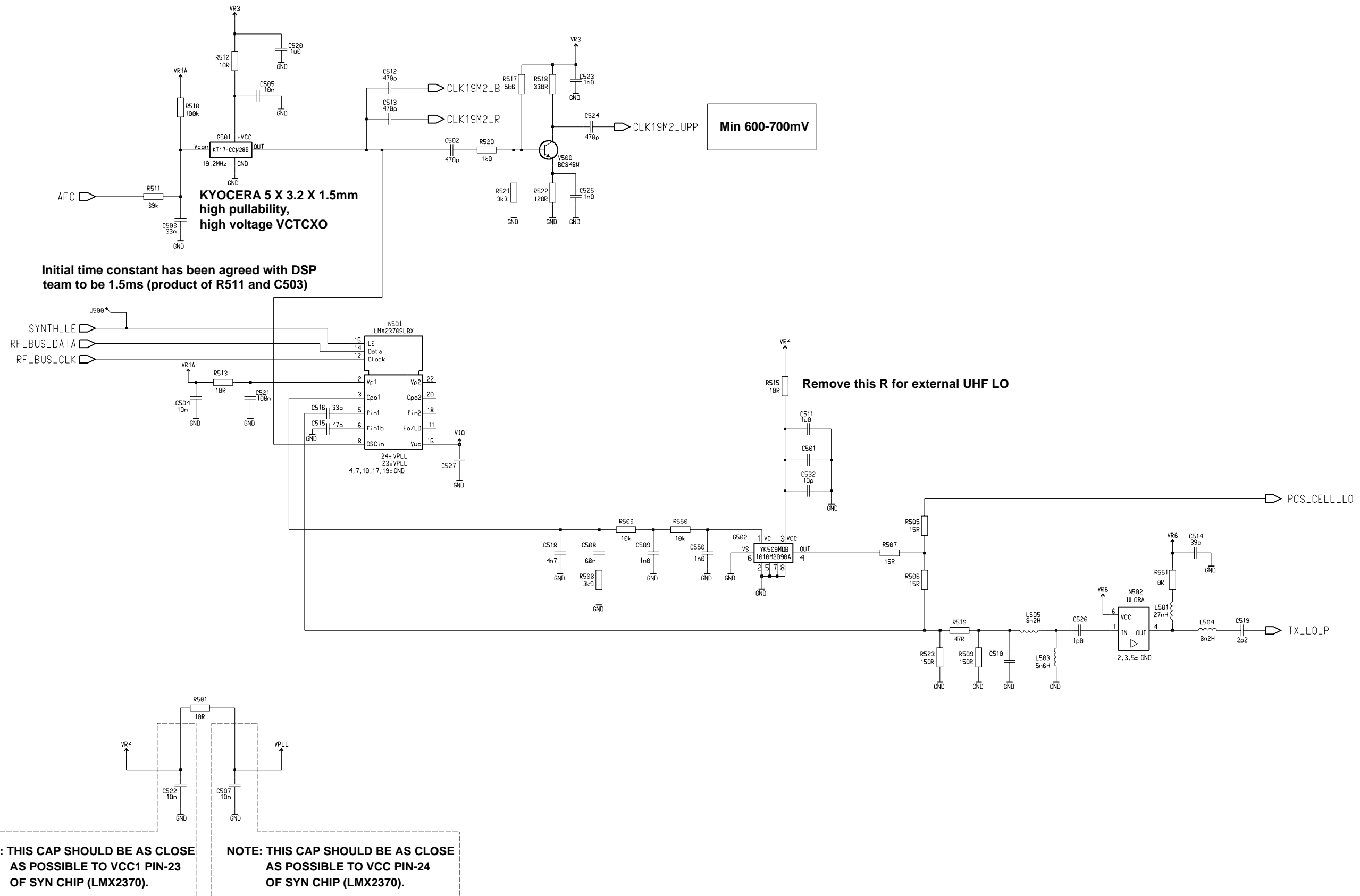

05 MAR 2002

System Connection

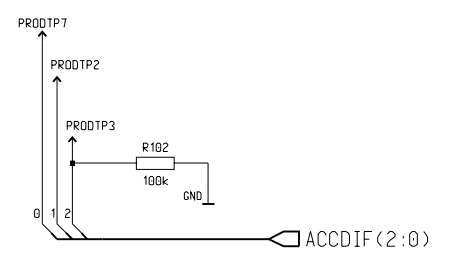
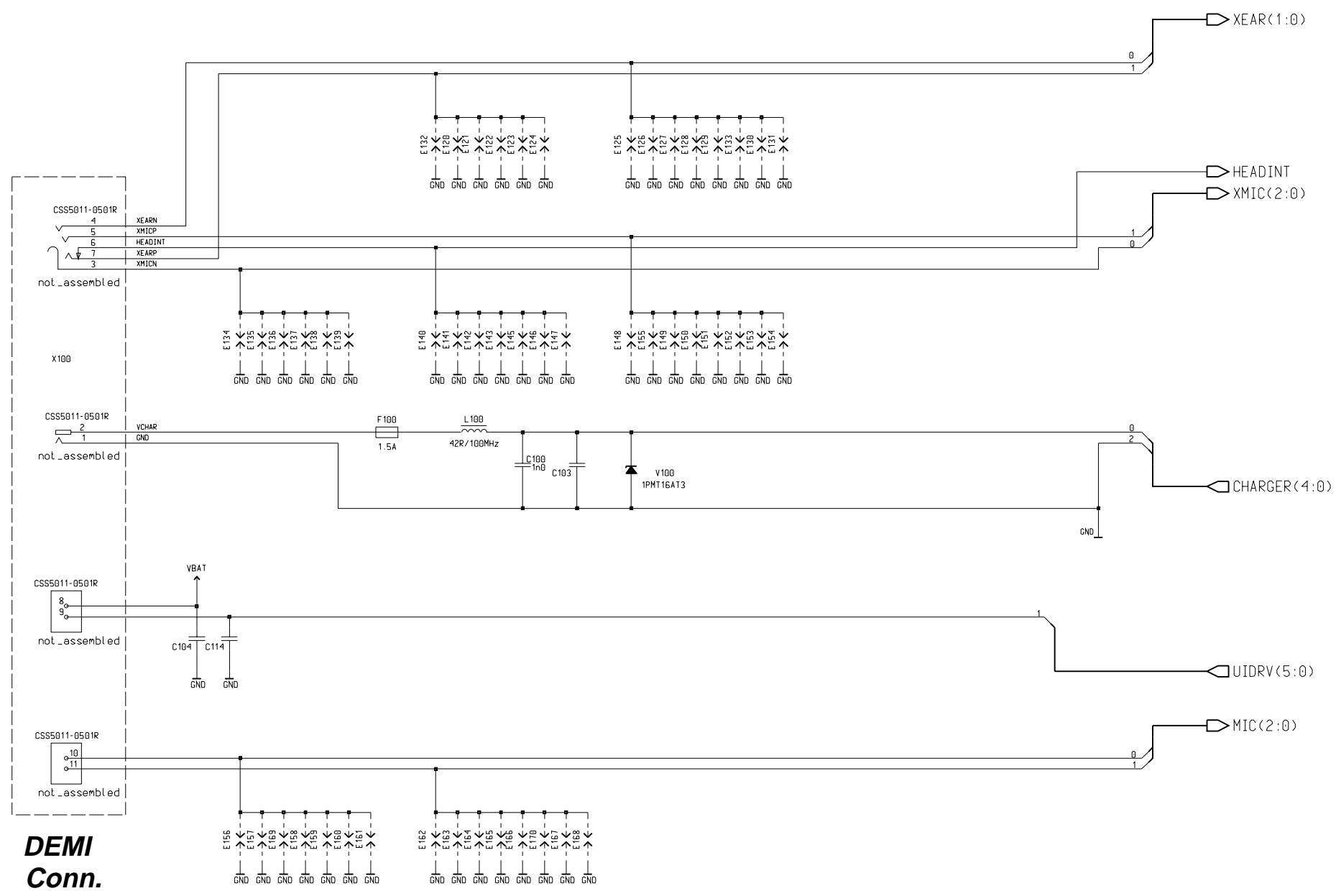

TPL

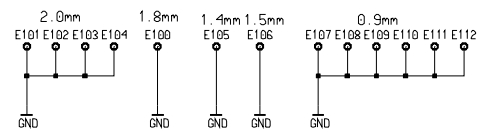
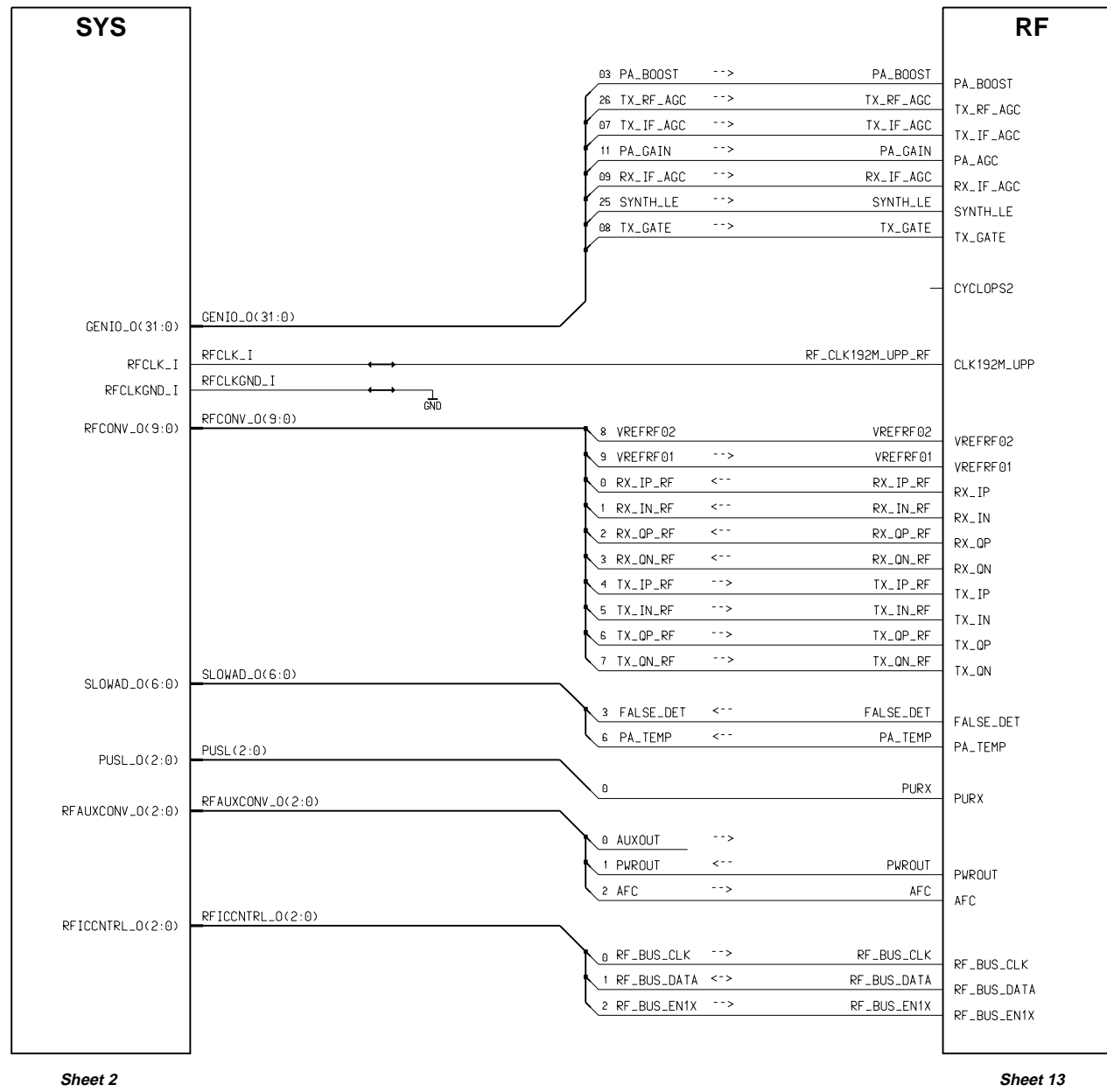

Memory

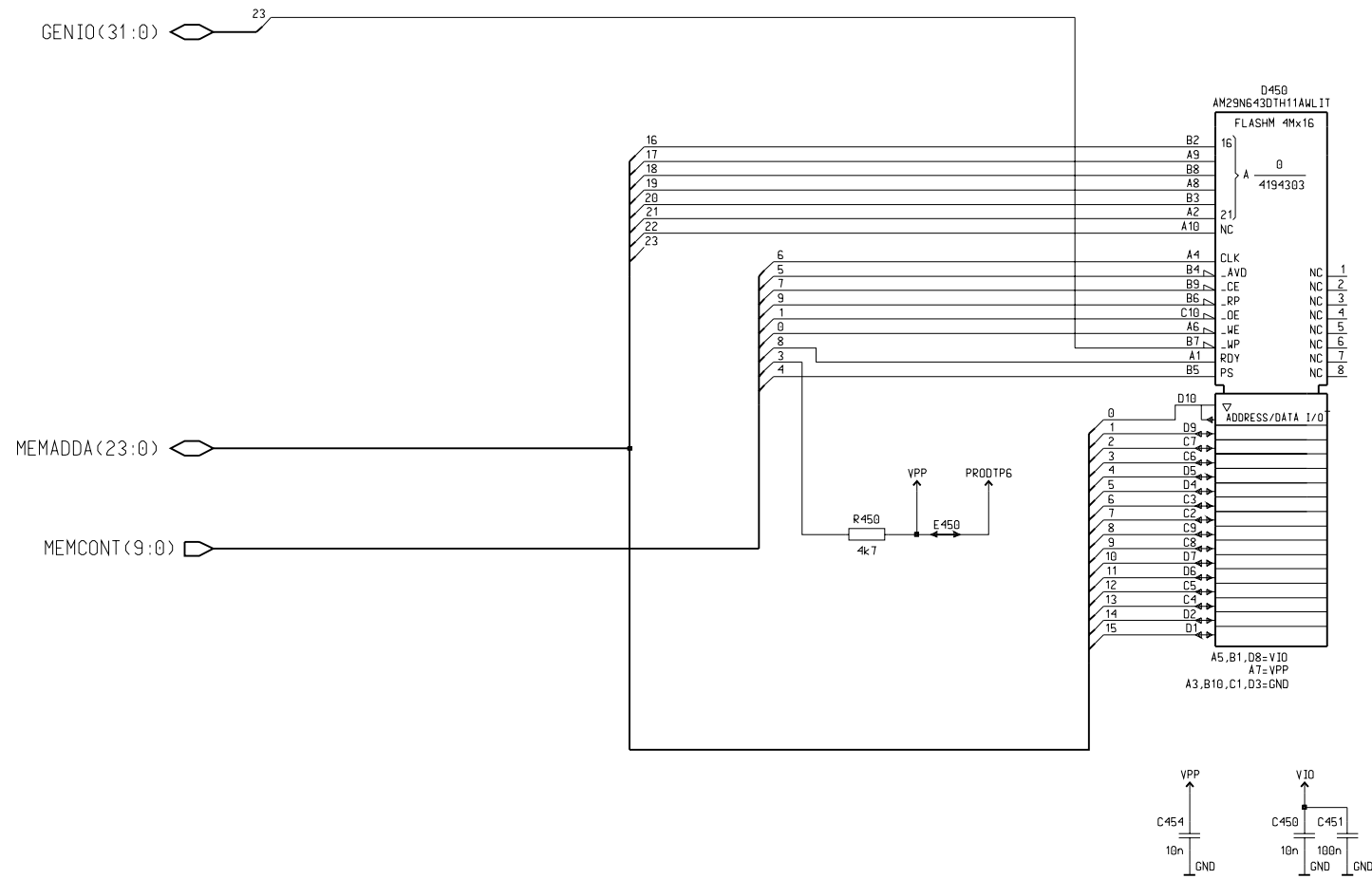

UEM Power

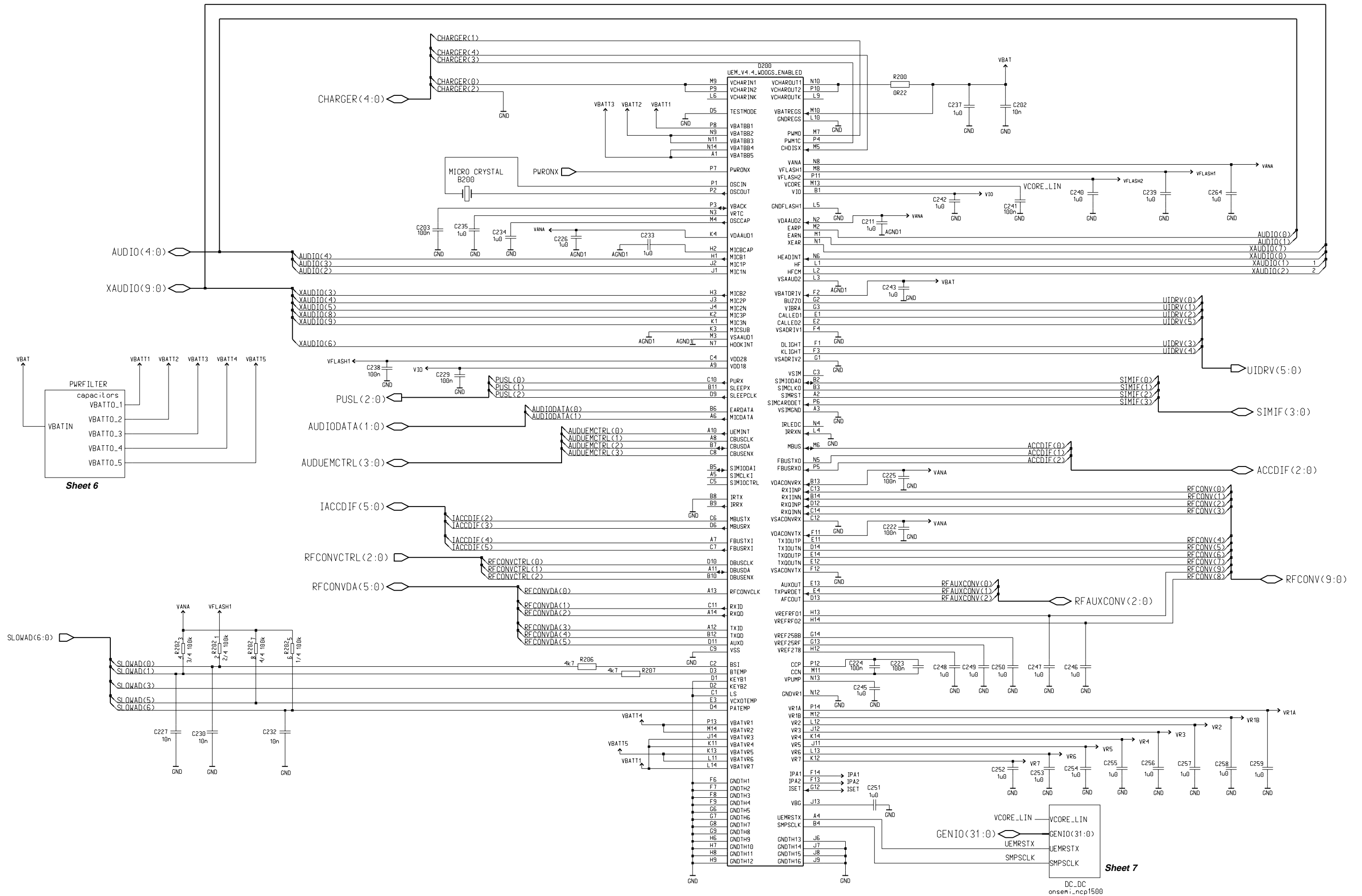

Sheet 6

Sheet 7

UEM Power Filter

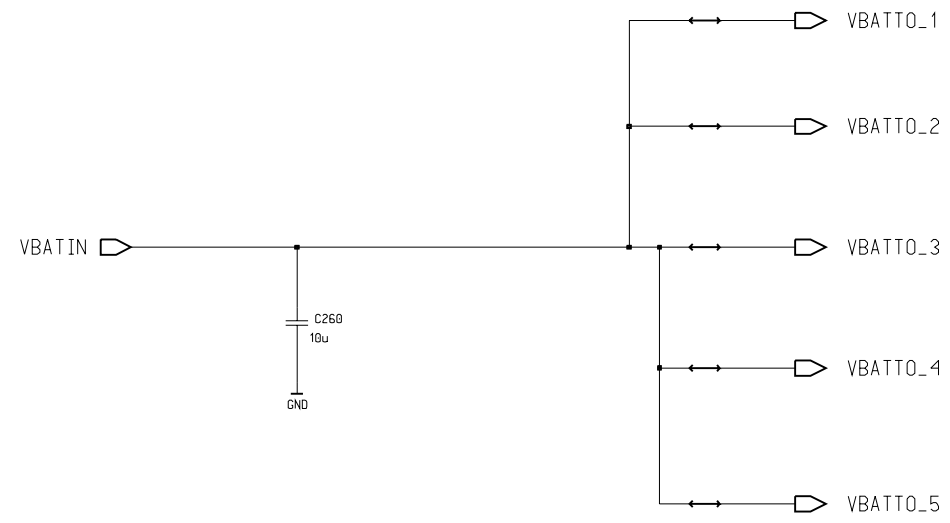

Key-UI

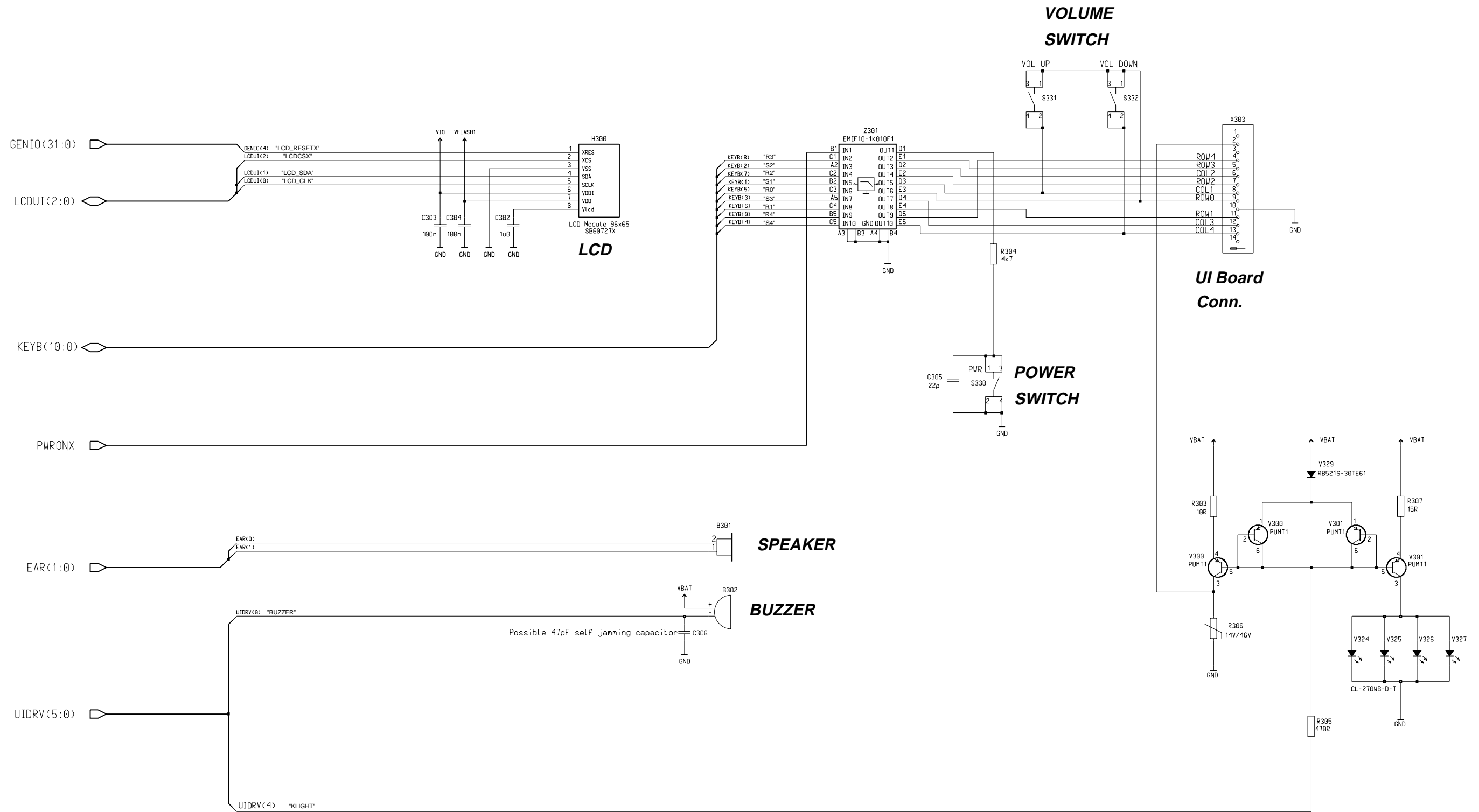

KEY_UI

UPP

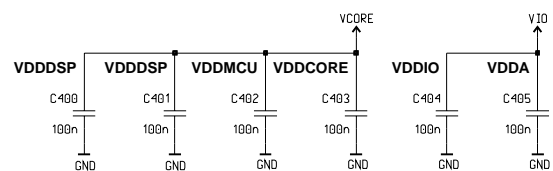
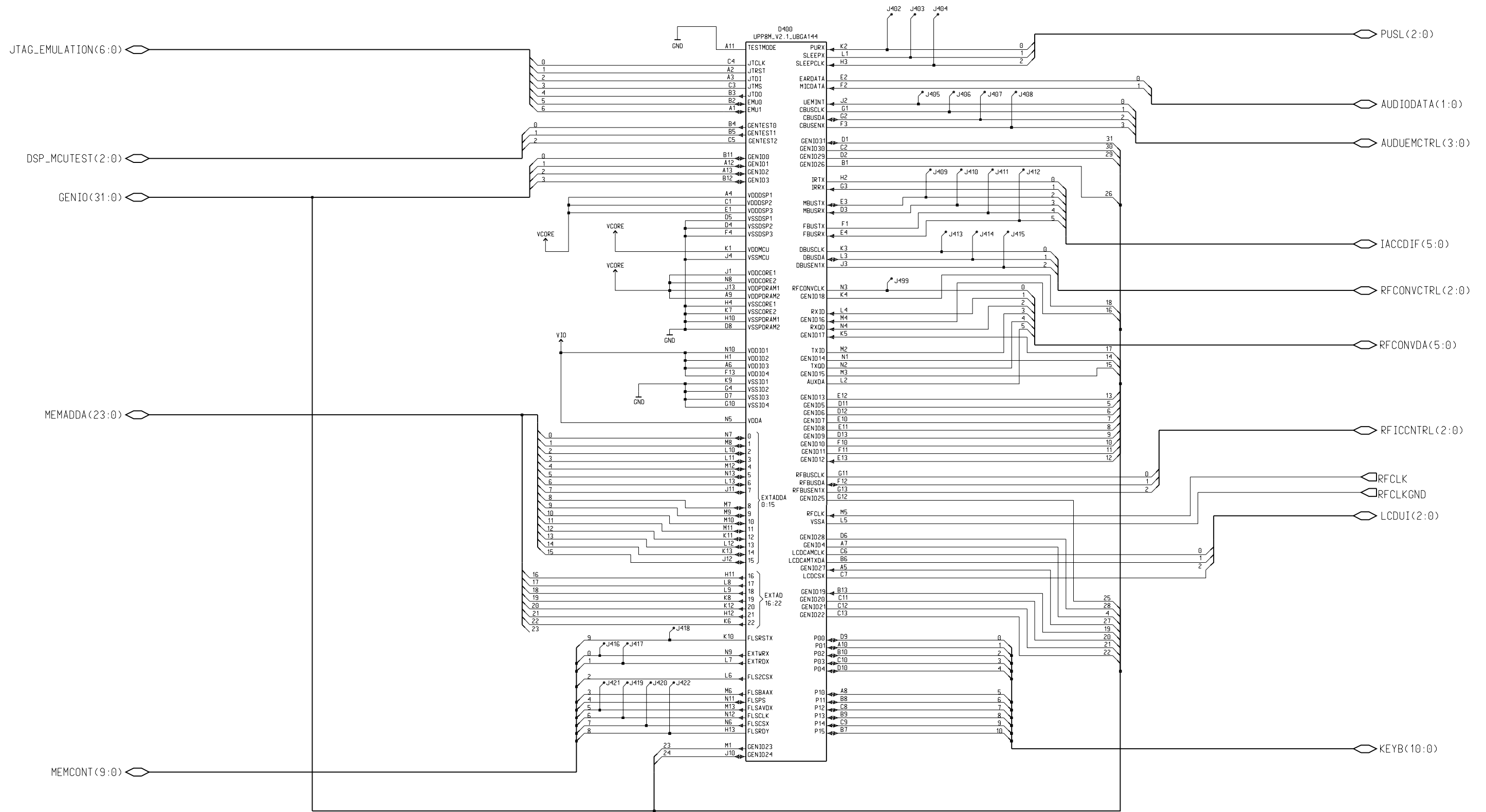

Component Layout - Top

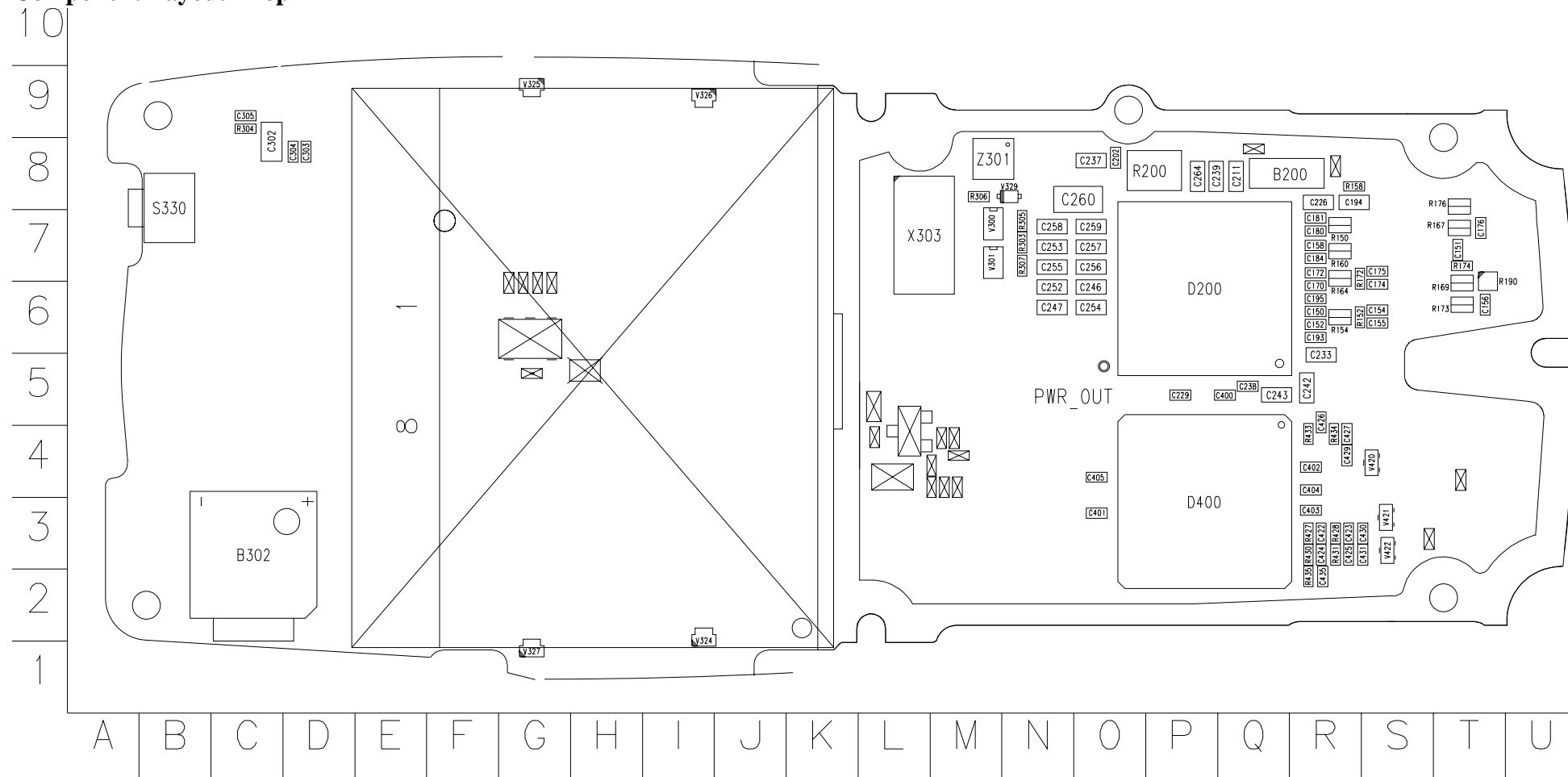

Component Layout - Bottom

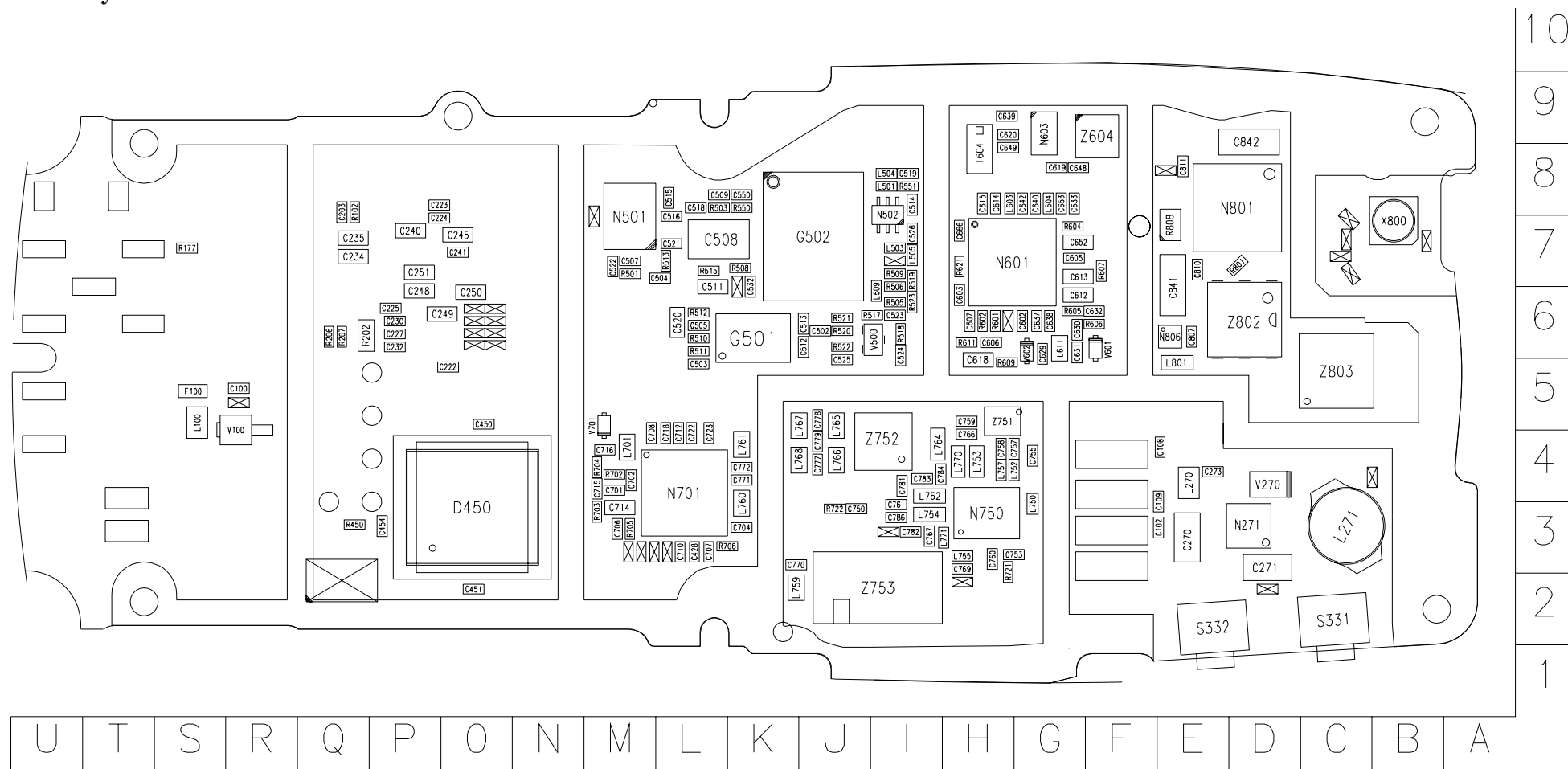

Component Layout - Top Values

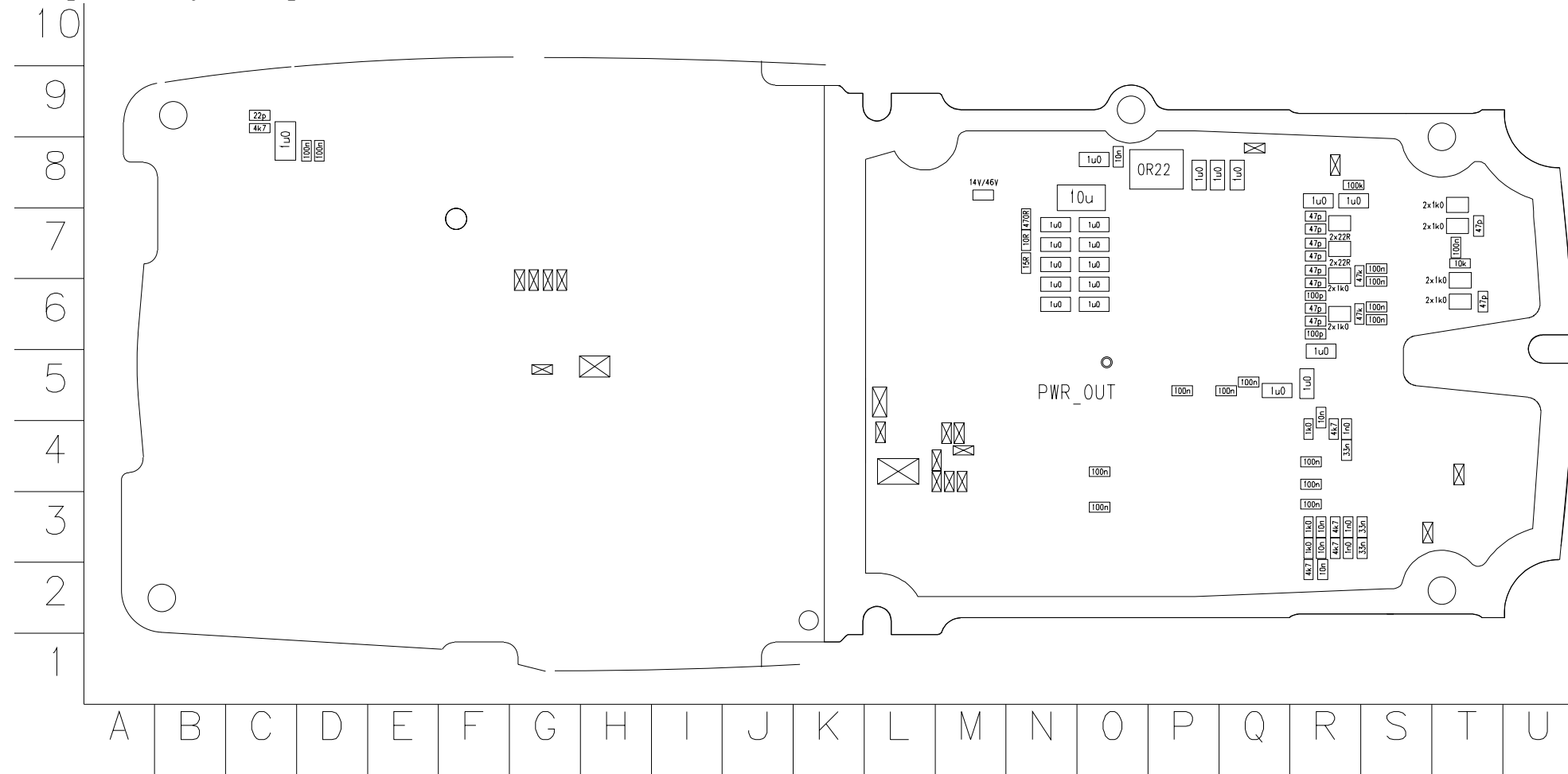

Component Layout - Bottom Values

